



BOSSINI

HIGH QUALITY SHOWER SYSTEMS

SCHEDA TECNICA - TECHNICAL SHEET

10/05/2021

Rev: 0

Codice - Code:

CA2001
PALOMA BRASS shut-off handspray set

Descrizione - Description:

Duplex doccia a pulsante in ottone con supporto fisso ottone, flessibile ottone DA cm 125.

Brass Shut-off handspray set with brass fixed bracket, double interlock brass hose cm 125.

Duschset: Brause aus Messing mit Abschaltssystem, Brausehalter Messing, Doppelwicklung, Brauseschlauch cm 125.

Tecnologia - Technology:



Ensemble Douchette d'arrêt laiton, support fixe laiton, flexible laiton double agrafage cm 125.

Conjunto ducha latón con pulsante de cierr, soporte fijo latón, flexible latón doble grapado cm 125.

Комплект лейка с фиксированным держателем и шлангом дв. фальцевания из латуни 125 см.

Immagine Prodotto - Product Image



Disegni - Drawings



Grafico di portata - Flow rate diagram

	rain
0	0,0
0,5	5,1
1	7,3
1,5	9,2
2	10,7
2,5	12,2
3	13,5
3,5	14,5
4	15,6
4,5	16,5
5	17,4
pressione bar	portata L/min

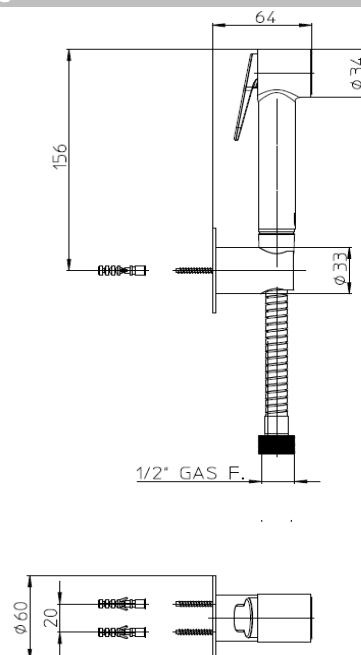
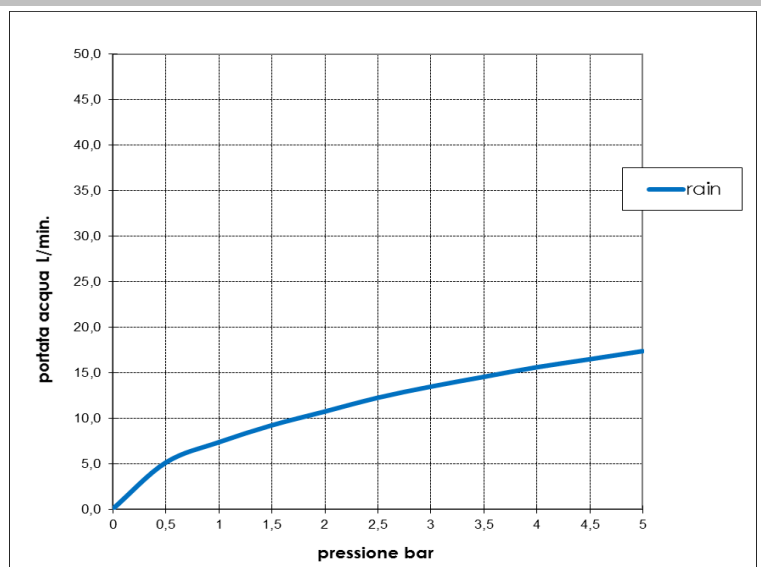

Caratteristiche idrauliche - Hydraulic features

	Pressione Pressure	Portata Flow rate	Solo per miscelatori termostatici Only for thermostatic mixers	
min	1 bar	7,3 L/min	Blocco di sicurezza Safety lock	--
max	5 bar	17,4 L/min	Temperatura acqua fredda Cold water temperature	--
Portata minima consigliata per buon funzionamento <i>Recommended minimum flow-rate for optimal performance</i>		5 L/min	Temperatura acqua calda Hot water temperature	--

Materiali - Materials

Supporto fisso CA2000: Ottone cromato con rosone in acciaio inox (AISI 304)
Doccia a pulsante B00470: Corpo in ottone e diffusore in plastica (ABS) cromati
Flessibile A03045: Ottone doppia aggraffatura

Fixed bracket CA2000: Chrome plated brass with stainless steel (AISI 304) wall rosette
Shut off handspray B00470: Chrome plated brass body and plastic (ABS) diffuser
Hose A03045: Double interlock brass hose

Certificazioni - Certifications

A03045:



Conformità' - Conformity

Chrome plating - EN 248